



NEWLONG®

3CM-3G/5G

AUTOMATIC BAGGING MACHINE

COMPACTLY DESIGNED GROSS WEIGHING AND BAGGING SYSTEM

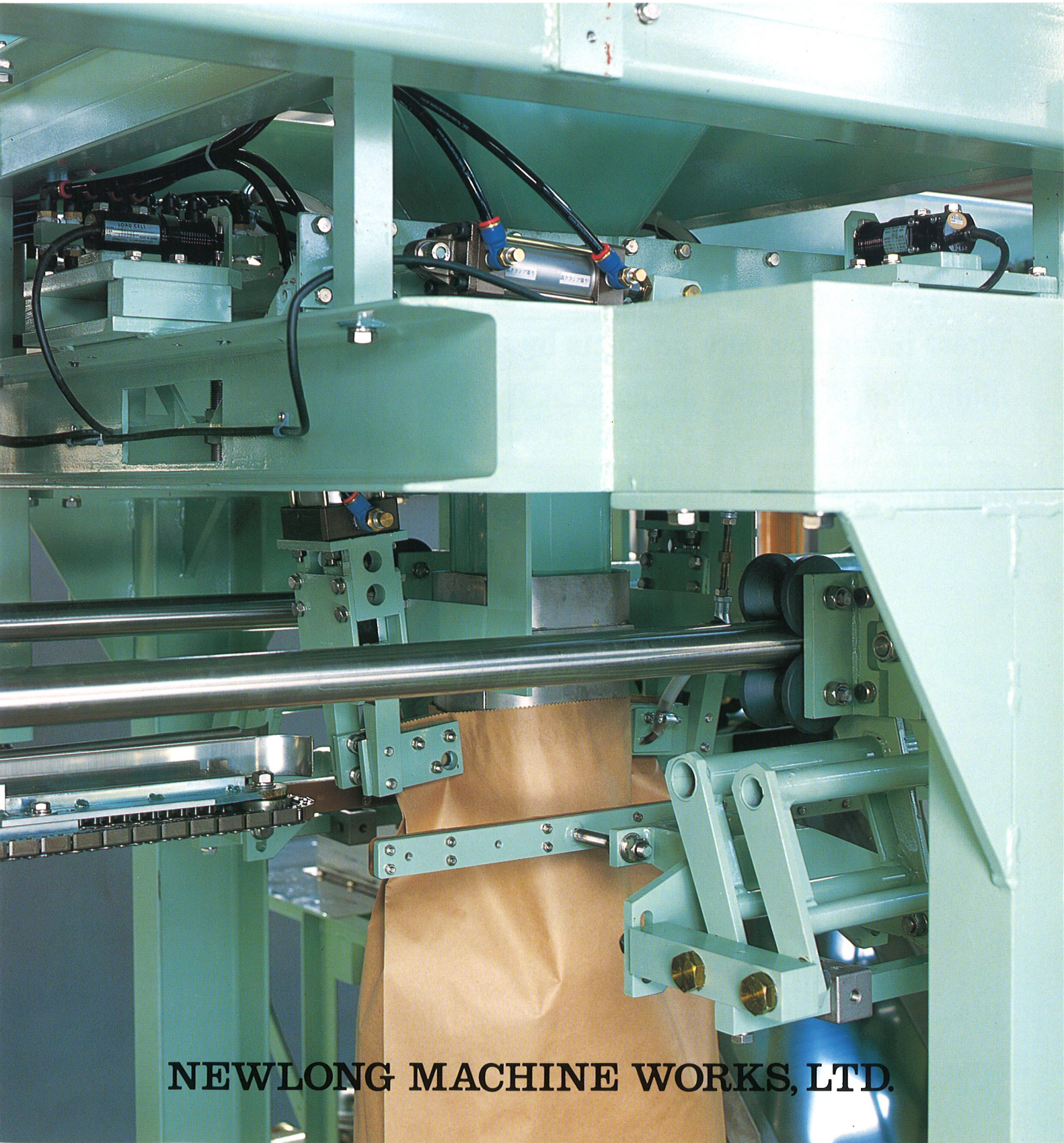

NEWLONG MACHINE WORKS, LTD.

GROSS-WEIGHING SYSTEM IDEAL FOR FULLY-AUTOMATIC BAGGING POWDERY PRODUCTS

3CM-3G

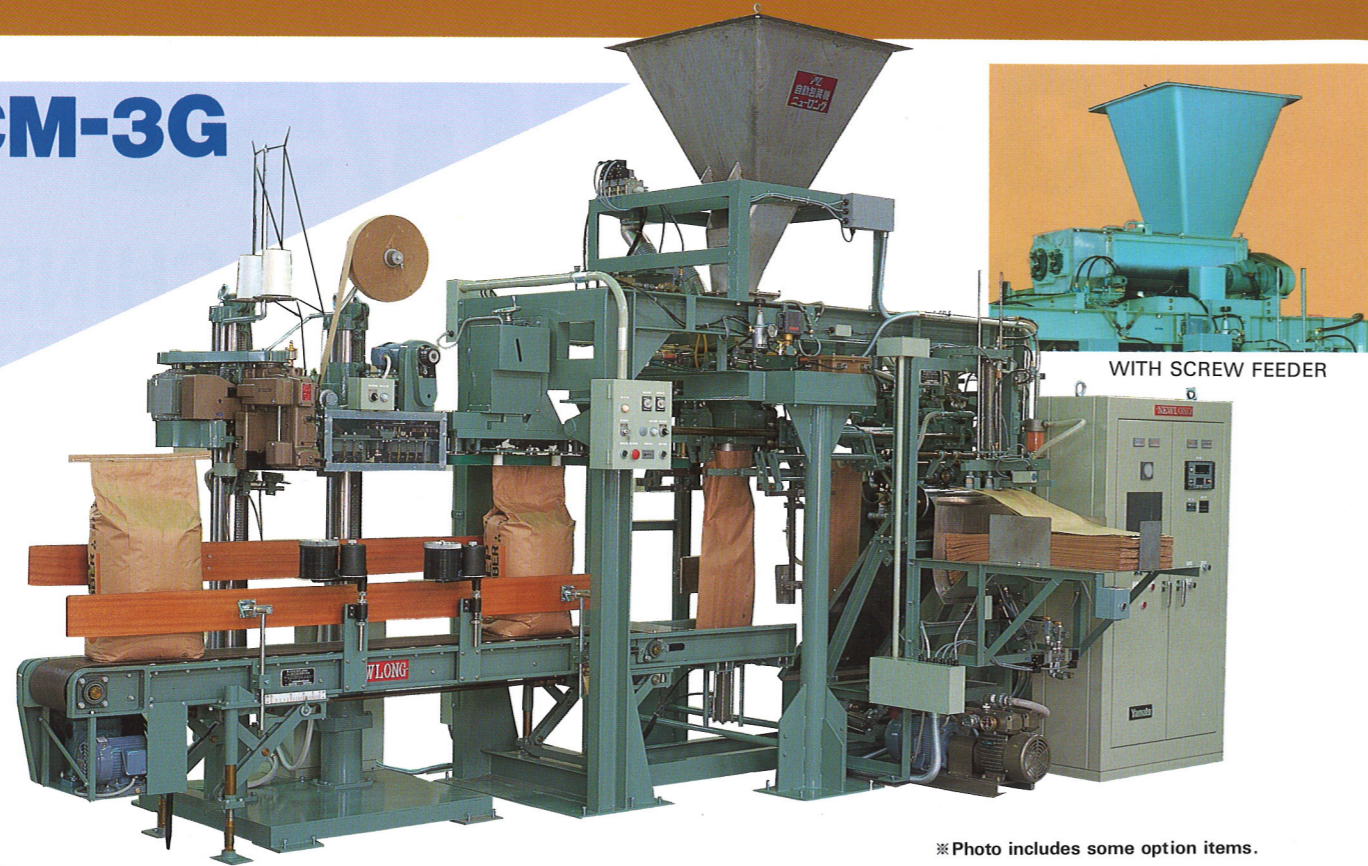

WITH SCREW FEEDER

※ Photo includes some option items.

Direct filling powdery products by gross-weighting system in which filling and weighing are done at the same time.

3CM-3G-2

Equipped with air ridding device (the first filling & the secondary air ridding by vacuum air inhler) for accelerating the machine speed of the Model 3CM-3G.

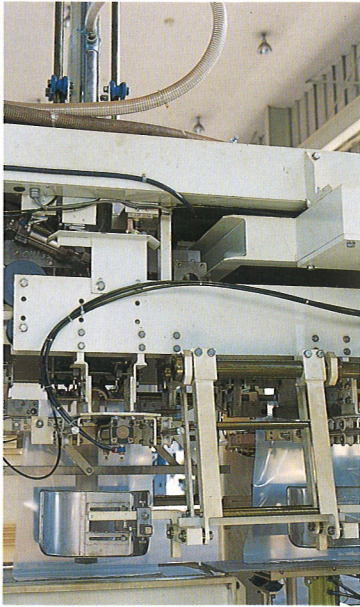
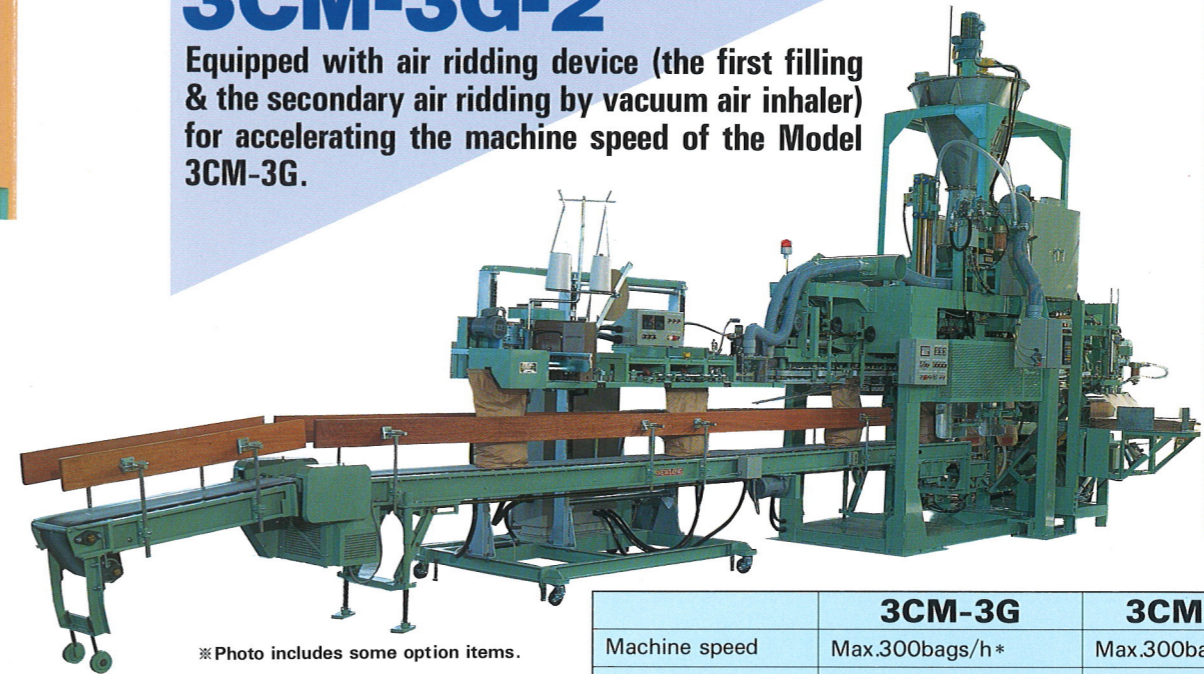

VACUUM AIR INHALER

※ Photo includes some option items.

	3CM-3G	3CM-3G-2
Machine speed	Max.300bags/h*	Max.300bags/h**
Accuracy	± 1/1000(20kg weighing)	± 1/1000(20kg weighing)
Paper bag size	BW380~500mm BL 650~850mm	BW380~500mm BL 650~850mm
Air consumption	400Nℓ/min(5kg/cm ² G)	600Nℓ/min(5kg/cm ² G)
Power required	Approx. 4.3KW***	Approx. 4.5KW***
Machine weight	Approx. 2.5t	Approx. 3.0t

OPTION

- Bag Printer
- Date/Code Printer
- Dust Extractor
- Air Ridding Device on Main Conveyor
- Bag Top Former for Air Ridding

* Depends on products and bag size.
** The machine speed of 3CM-3G-2 is faster than 3CM-3G, running on the same products and bag size.
*** With Model A2-P2L(DS-6) bag closing machine.

● Specifications subject to change without notice.

3CM-5G

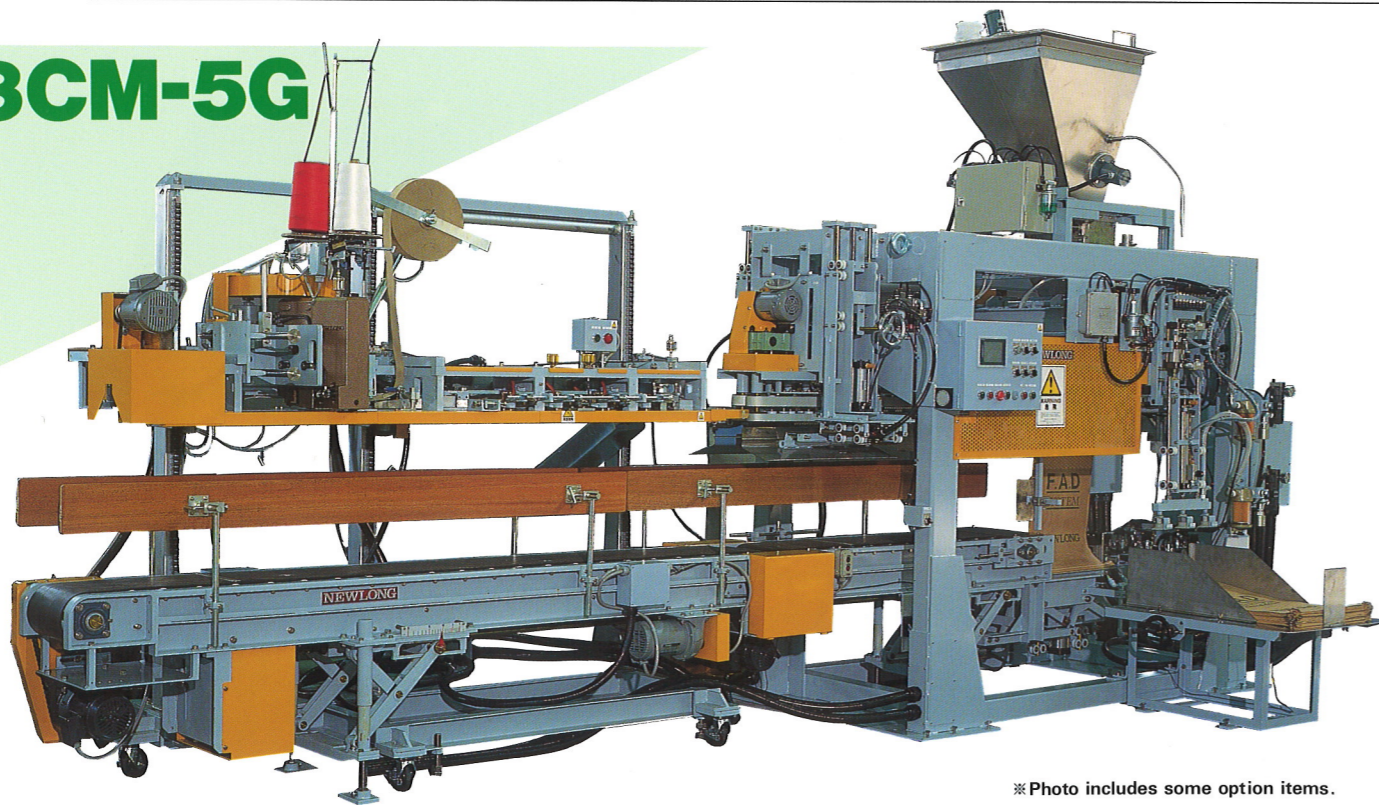

※ Photo includes some option items.

3CM-5G is designed to place bags at fill-chute directly by swing type feeder, which is different from that of 3CM-3G.

3CM-5G-2

Equipped with air ridding device (the first filling & the secondary air ridding by vacuum air inhler) for accelerating the machine speed of the Model 3CM-5G.

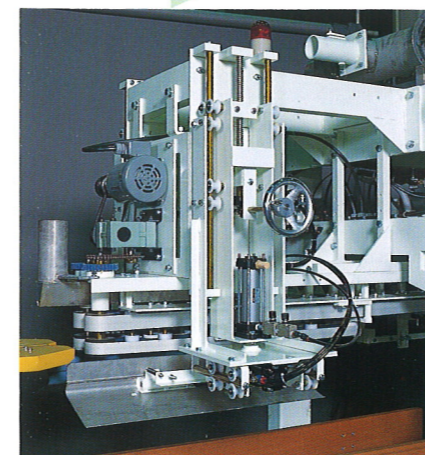

BAG TOP FORMER FOR AIR RIDDING (OPTION)

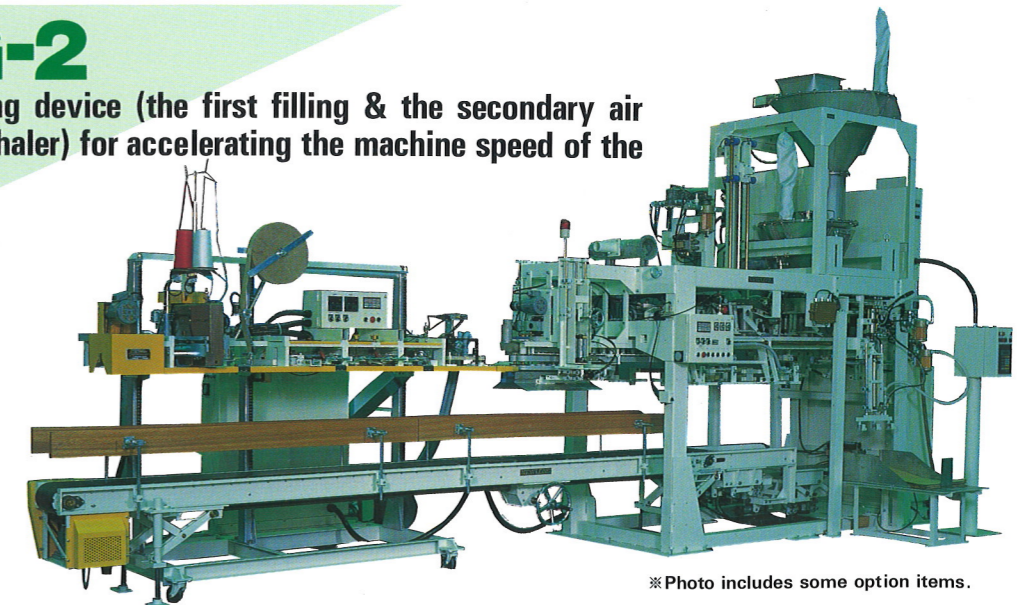

※ Photo includes some option items.

	3CM-5G	3CM-5G-2
Machine speed	Max.230bags/h*	Max.230bags/h**
Accuracy	± 1/1000(20kg weighing)	± 1/1000(20kg weighing)
Paper bag size	BW380~500mm BL 650~850mm	BW380~500mm BL 650~850mm
Air consumption	300Nℓ/min(5kg/cm ² G)	450Nℓ/min(5kg/cm ² G)
Power required	Approx. 3.2KW***	Approx. 3.5KW***
Machine weight	Approx. 2.5t	Approx. 3.0t

OPTION

- Bag Printer
- Date/Code Printer
- Dust Extractor
- Air Ridding Device on Main Conveyor
- Bag Top Former for Air Ridding

* Depends on products and bag size.
** The machine speed of 3CM-5G-2 is faster than 3CM-5G, running on the same products and bag size.
*** With Model A2-P2L(DS-6) bag closing machine.

● Specifications subject to change without notice.

VARIETY CHOICE OF FEEDER DEPENDING ON PRODUCTS

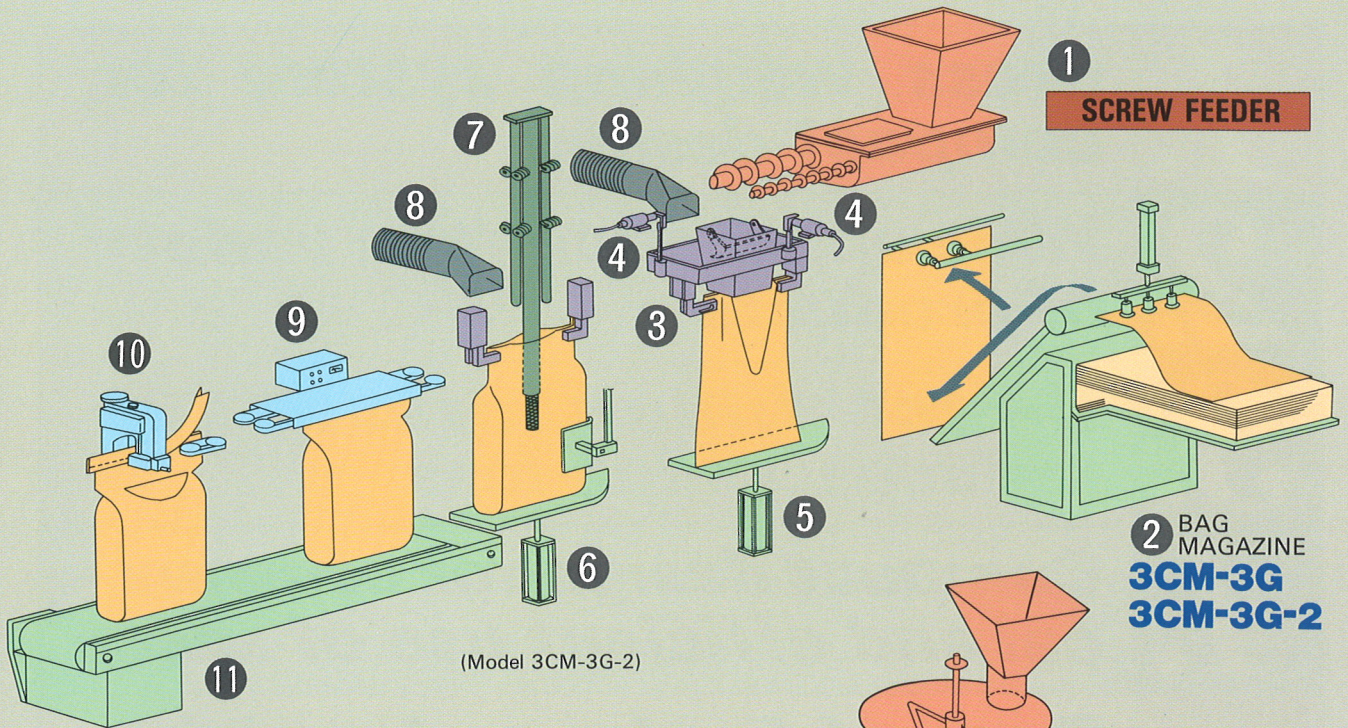

(Model 3CM-3G-2)

1 SCREW FEEDER

2 BAG MAGAZINE
3CM-3G
3CM-3G-2

- 1 PRODUCTS FEEDER
- 2 BAG MAGAZINE
- 3 BAG OPENER & FILLER
- 4 LOAD-CELL
- 5 BAG BOTTOM TAPPER ON THE FIRST FILLING STATION
- 6 BAG BOTTOM TAPPER ON THE SECOND AIR RIDDING STATION
(only for Model 3CM-3G-2, 3CM-5G-2)
- 7 VACUUM AIR INHALER
(only for Model 3CM-3G-2, 3CM-5G-2)
- 8 DUST EXTRACTING PIPES
- 9 HEAT SEALER (or OVER TAPE SEALER)
- 10 BAG CLOSING MACHINE
- 11 MAIN CONVEYOR

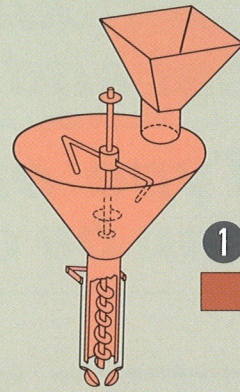

1 AUGAR

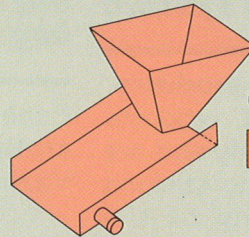

1 MAGNETIC FEEDER

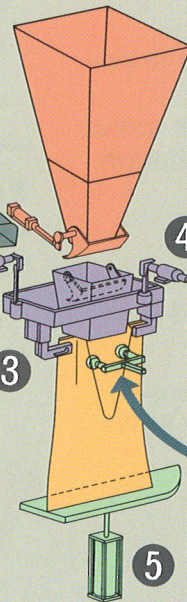

1 CUT-OFF GATE

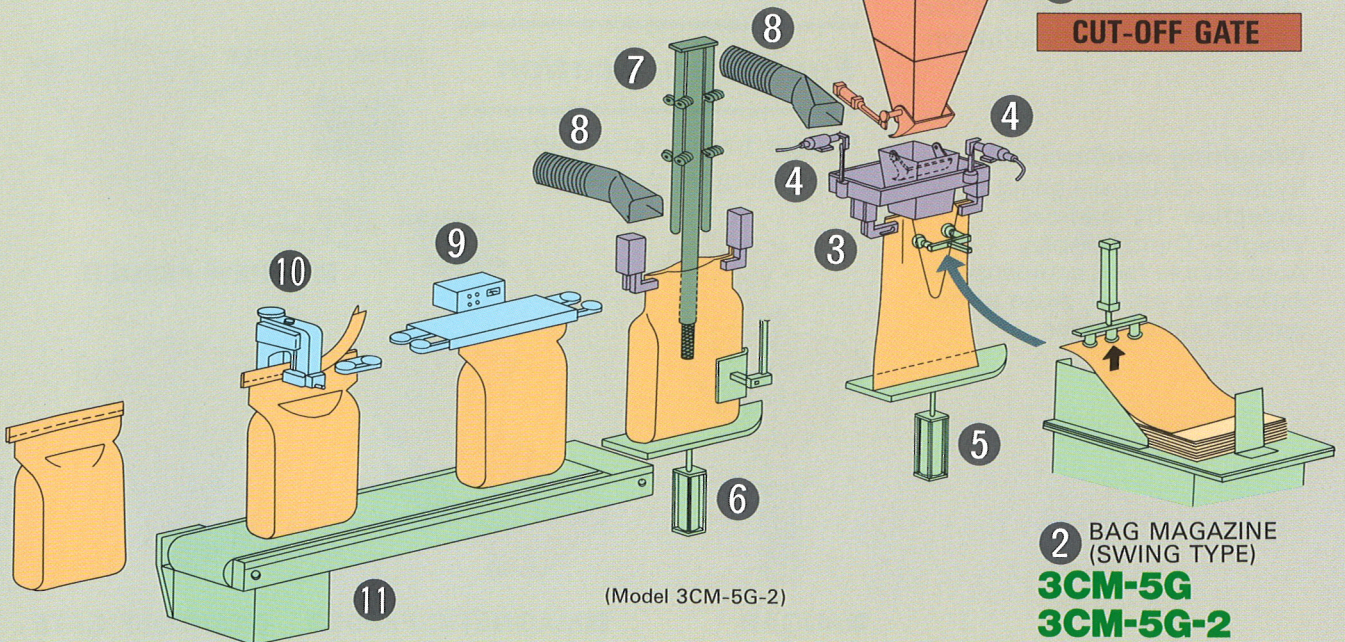

(Model 3CM-5G-2)

2 BAG MAGAZINE
(SWING TYPE)
3CM-5G
3CM-5G-2

NEWLONG'S CONSTANT RESEARCH AND ACCUMULATED EXPERIENCE

- 1. Gross weighing system for compact design**
- 2. Wide application for a variety of products**
- 3. Direct filling drastically reduces weigh loss**
- 4. Compact design for economical and efficient use of space**
- 5. Type of feeder and weigher can be chosen to suit product**

Gross-weighing system

- ***Ideal for powdery products**
Unlike net-weighing, products fill into a bag directly and are weighed, causing no sticking and no dispersing of the products.
- ***Compact, less space required**
Compact design saves space and height for installation.

Weighing mechanism
System - Gross weighing
Detection - By load-cell
Weight - Digital display
Auto dribble feed compensator,
Auto zero adjust, Auto under weight compensator

Any kinds of open-mouth bag can be used

Paper, polyethylene, woven-cloth, or paper-cloth bag. Various bag size available.

Safety and interlock system

- *Mis-clamped and mis-opened bag detector
- *Optional items
Detection of no bag on magazine, thread break detector, thread scanner, crepe-tape scanner, and detection of air-pressure drop

Feeder application

Feeder has a variety choice, depending on product.

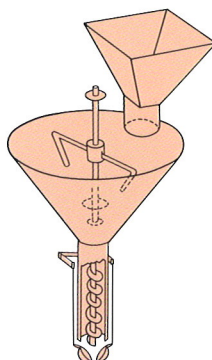

■AUGAR

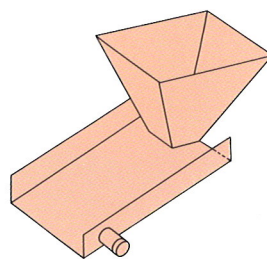

■MAGNETIC FEEDER

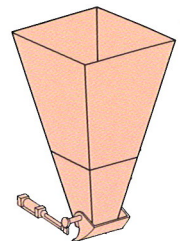

■CUT-OFF GATE

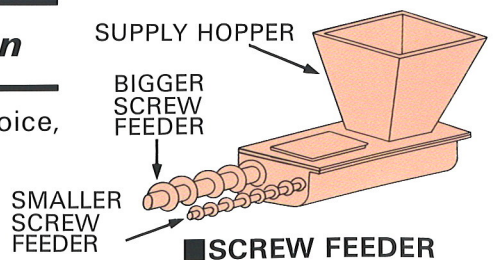

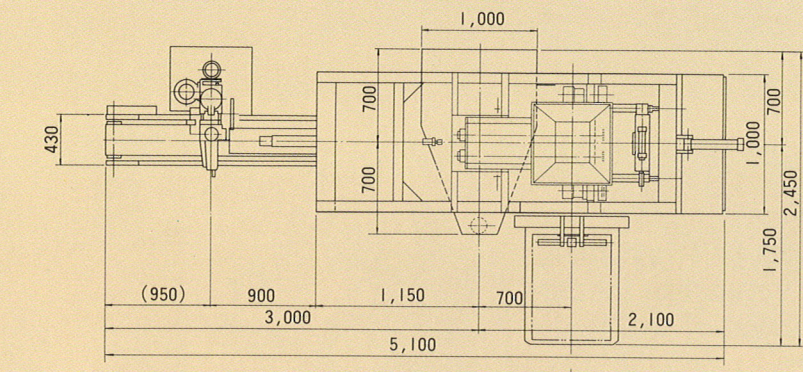

3CM-3G

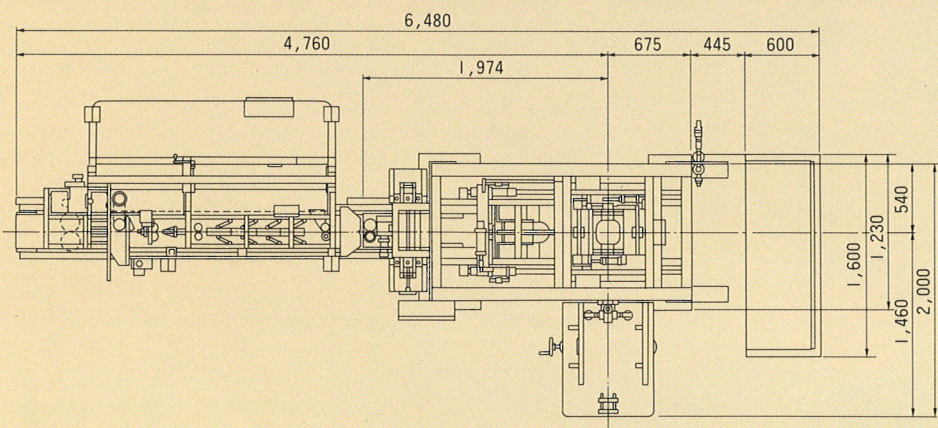
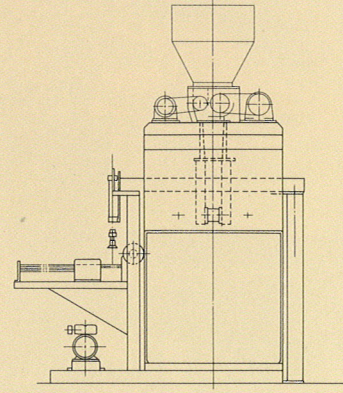
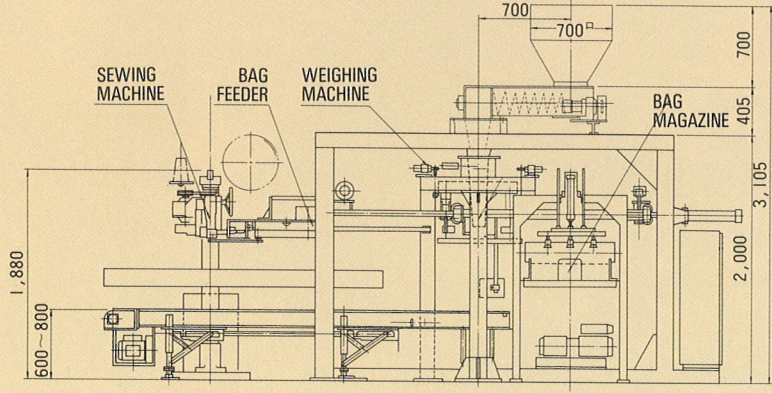

3CM-5G

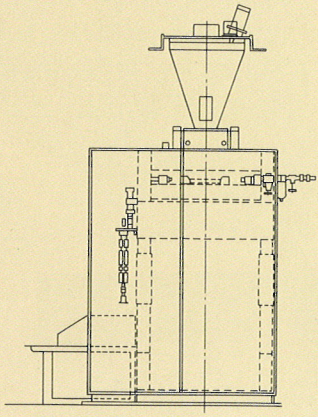
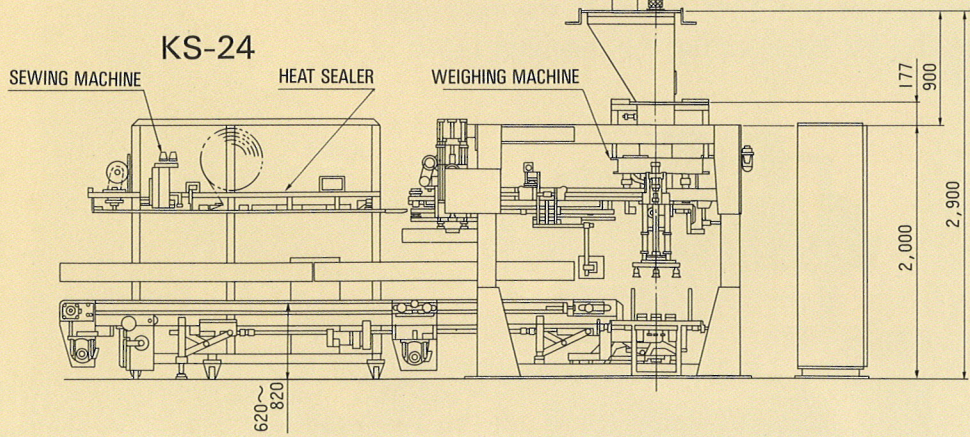

NEWLONG MACHINE WORKS, LTD.

HEAD OFFICE: 14-14, Matsugaya 1-chome, Taito-ku, Tokyo 111-0036, Japan
 Home Page <http://www.newlong.com/>

OVERSEAS OFFICE:
 NEWLONG PACKAGING MACHINERY (Beijing) CO., LTD.
 NEWLONG PACKAGING MACHINERY (Beijing) CO., LTD. Shanghai Branch
 NEWLONG (Hong Kong) CO., LTD.
 NEWLONG TAIWAN MACHINE CO., LTD.
 NEWLONG SINGAPORE PTE.LTD.
 NEWLONG MALAYSIA SDN.BHD. (Selangor)
 NEWLONG MALAYSIA SDN.BHD. (Johor Bahru)
 PT NEWLONG INDONESIA
 NEWLONG (THAILAND) LTD.
 NEWLONG FZE (Dubai)
 NEWLONG MACHINES (India)
 NEWLONG HOLLAND B. V.
 AMERICAN-NEWLONG INC.
 NEWLONG DE MEXICO S. A. DE C. V.
 NEWLONG HASEBRAS MAQUINAS INDUSTRIAIS LTDA.

Fax:(81) 3-3843-0260 Tel:(81) 3-3843-0269
 Fax:(86) 10-6127-2475 Tel:(86) 10-6127-1866
 Fax:(86) 21-6432-5512 Tel:(86) 21-6432-5955
 Fax:(852) 2577-2876 Tel:(852) 2576-3676
 Fax:(886) 2-2522-1420 Tel:(886) 2-2571-6524
 Fax:(65) 265-1994 Tel:(65) 265-0901
 Fax:(60) 3-7727-6000 Tel:(60) 3-7728-8323
 Fax:(60) 7-356-0257 Tel:(60) 7-356-0254
 Fax:(62) 21-7919-5947 Tel:(62) 21-7919-5945
 Fax:(66) 2-391-5508 Tel:(66) 2-391-1171
 Fax:(971) 4-881-9882 Tel:(971) 4-881-7188
 Fax:(91) 22-8901704 Tel:(91) 22-8912754
 Fax:(31) 20-653-2416 Tel:(31) 20-653-2350
 Fax:(1) 317-786-522 Tel:(1) 317-787-9421
 Fax:(52) 33-33448084 Tel:(52) 33-3344-8086
 Fax:(55) 11-5073-9084 Tel:(55) 11-5073-9744

NEWLONG®  are the registered trademarks of Newlong Machine Works, Ltd